

# **SIRIUS CAPACITOR MODULE**

## User Manual

Model number: 1000-12-B-0.6C-A-G  
Version 1.0; Release Date: June 2019

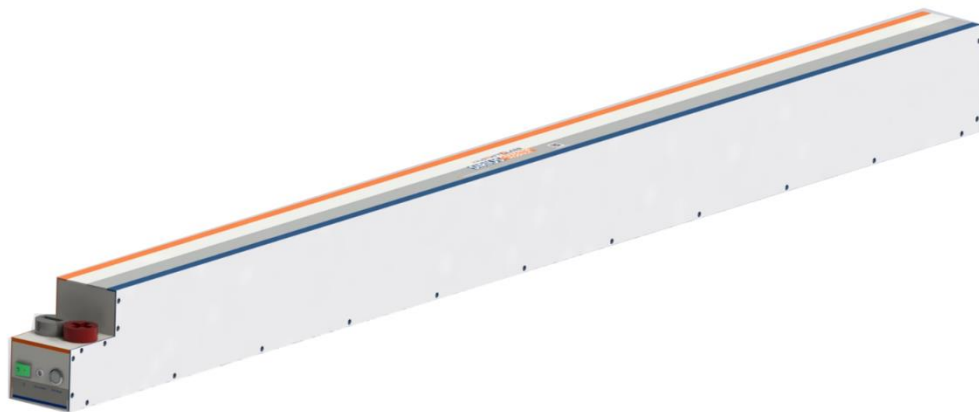

Author:

Mamoona Khalid

## **Introduction**

The Sirius Capacitor Module (“Sirius”) is supercapacitor-based storage that uses supercapacitors as storage cells instead of chemical cells. Kilowatt Labs’ proprietary balancing, control and charge retention algorithms control the operation of the supercapacitor-based modules, making Sirius a safe, efficient and effective alternative to chemical batteries wherever chemical batteries are deployed.

## **Legal Provisions**

No part of this User Manual (“Manual”) may be reproduced, or transmitted, in any form or by any means, without the prior written permission of Kilowatt Labs, Inc. (“Kilowatt” or the “Company”). Specifications in this Manual are subject to change without notice. While every attempt has been made to make the Manual accurate and up-to-date, users are cautioned that product improvements may cause the Company to make changes to specifications without advance notice. Users are encouraged to consult the Company or its Resellers before using the Manual. Neither the Company nor its Resellers shall be liable for any indirect, incidental, or consequential damages under any circumstances caused by reliance on the material presented, including, but not limited to, omissions, typographical errors, arithmetical errors or listing errors in the content material. The content of this manual shall not be modified without the written authorization of the Company.

## **Trademarks**

All trademarks are recognized, even if not explicitly identified as such. Kilowatt Labs® is a registered trademark of the Company.

## Table of Contents:

1.	Safety Instructions: .....	4
1.1	Symbols Convention: .....	4
1.2	Safety Precautions: .....	4
1.3	Modules Connection Safety Precautions:.....	6
1.4	Shipping: .....	6
1.5	Qualified Installer:.....	7
2.	Product Introduction:.....	7
2.1	Product Part Number .....	7
2.2	Product Overview: .....	7
2.2.1	Appearance: .....	7
2.2.2	Mechanical Drawings:.....	8
2.2.3	Dimensions and Weight: .....	9
2.3	Product Description: .....	9
3.	Module Installation:.....	10
3.1	Inspection:.....	10
3.2	Safety Gear:.....	10
3.3	Unpacking and Contents Check: .....	11
4.	Operation Procedures:.....	11
4.1	Module Configuration:.....	11
5.	Connecting Modules in Parallel or in Series: .....	12
5.1	Parallel Connection of Sirius Modules: .....	12
5.2	Series Connection of Sirius Modules: .....	13
6.	Recovery Procedure:.....	14
7.	Automatic Safety Alarm: .....	15
8.	Trouble Shooting:.....	15
9.	Features: .....	16
9.1	Key Features:.....	16
9.2	Physical features: .....	17
10.	Shelf Life:.....	17
11.	Maintenance: .....	17
12.	Disposal:.....	17
13.	Test Procedures: .....	17
13.1	Round Trip Efficiency Test:.....	17

## 1. Safety Instructions:

This manual contains instructions for unpacking, mounting, installation and operation of a Sirius Module. Please read this manual carefully before operating the system and follow all warnings and safety instructions to prevent accidents. The Sirius Module must be installed by trained personnel.

### 1.1 Symbols Convention:

Safety instructions and general information that appear in this manual are described.



**Caution!**

'Caution' indicates hazardous situation which, if not avoided could result in minor or moderate injury.



**Warning!**

'Warning' indicates hazardous situation which, if not avoided could result in major injury or death.



**Danger!**

'Danger' indicates hazardous situation which, if not avoided could result in serious injury or death.



**Note!**

'Note' provides tip that are valuable for optimal operation of your product.

### 1.2 Safety Precautions:

The Sirius Modules are designed to provide years of trouble-free operation. Proper handling is required to avoid damage to the Module. In particular the following precautions should be observed.

- **Personal Safety:**

- Always wear proper personal protective equipment (eyes protection, gloves and safety shoes).
- Always make sure the charger is set as recommended.
- Always make sure the chargers are disconnected while working on the Modules.

- **Module Safety:**

- Do not subject the Module to strong impact.
- Do not crush or puncture the Module.
- Do not dispose the Module in a fire.
- Do not charge the Module when the temperature is below -30°C.
- Do not charge the Module when the temperature is above 80°C.
- Do not operate the Module above the specified voltage.
- Under no circumstance charge/discharge the Module at more than 50A.
- Under no circumstance must the charging voltage exceed 13.5 V<sub>dc</sub> for more than 60 seconds.
- Do not expose the Module to temperature in excess of 80°C.
- Do not place the Module near a heat source, such as a fireplace.
- Do not disassemble the Module under any circumstances.
- Do not lift the Module by the terminal posts.
- Do not touch the Module with wet hands.
- Do not expose the Module to moisture or liquids.
- Keep the Module away from children and animals.
- Ensure precautions to prevent short-circuit under all circumstances.
- Do not connect or disconnect terminals from the Module without first disconnecting the load.
- Do not touch the terminals with conductors while the Module is charged. Serious burns, shock, or material fusing may occur.
- Protect surrounding electrical components from incidental contact.
- When connecting to external devices ensure that galvanic isolation does not exceed 1500V.
- Do not use the Module in open-environment, in rain or in a place exposed to water and other liquids.
- Do not subject the Module to high pressure.
- Do not place any objects on top of the Module.
- Do not step on the Module.
- Mount the Modules only in horizontal direction.
- Do not drop the Module. Internal damage may occur that will not be visible.
- Do not stack Modules once they have been removed from the packaging, instead the Modules should be placed on shelving.
- In case the Module is physically damaged due to any event, do not install and energize the Module under any circumstances and immediately contact your Reseller.



**Note!**  
Do not stack more than 2 Modules.

### 1.3 Modules Connection Safety Precautions:

- All Modules must be at 100% SOC before connecting in Series or in Parallel.
- The maximum number of Modules that can be connected in series is 8.
- Do not connect more than 8 Modules in Series.
- There is no limit on the Modules while connecting in parallel.
- Modules cannot be connected in Series-Parallel combination under any circumstance.



**Note!**  
If you want to connect more than 8 Modules in Series, please contact your Reseller.

### 1.4 Shipping:

Sirius Modules are shipped out via Air and Sea.

- If you receive the Modules shipped by Air, please follow the instructions given below:
  - Carefully remove the nails from all the four sides of the wooden box and open it.
  - Remove the foam and cling wrap and open the carton box and lift the Module manually.
- If you receive the Modules shipped by Sea, please follow the instructions below:
  - Carefully remove the Module from the pallets after cutting the packing strip holding the Modules to the shipping pallets.
  - Open the carton box and lift the Module manually.



**Danger!**  
The module must be removed from the carton by lifting the module from base.  
Do not remove the module by the terminal posts.

**1.5 Qualified Installer:**

Selling and installation of this Module is only through the Company's Resellers who are trained on installation, operation and maintenance of the Sirius Modules.

**2. Product Introduction:**

**2.1 Product Part Number**

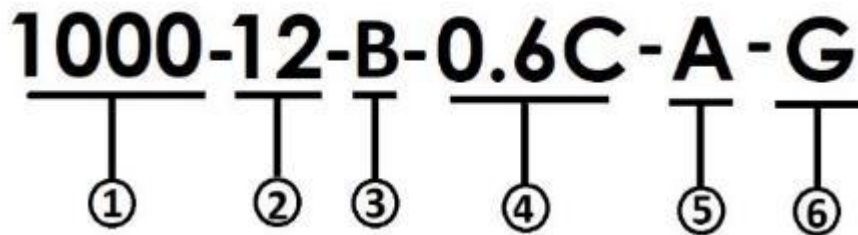

- 1) Capacity of Module in Wh
- 2) Nominal Voltage of the Module
- 3) Terminals are on the Front Side
- 4) Maximum Charge Rate of the Module
- 5) With Alarm
- 6) General Module

**2.2 Product Overview:**

**2.2.1 Appearance:**

The appearance of the Sirius Capacitor Module is shown below:

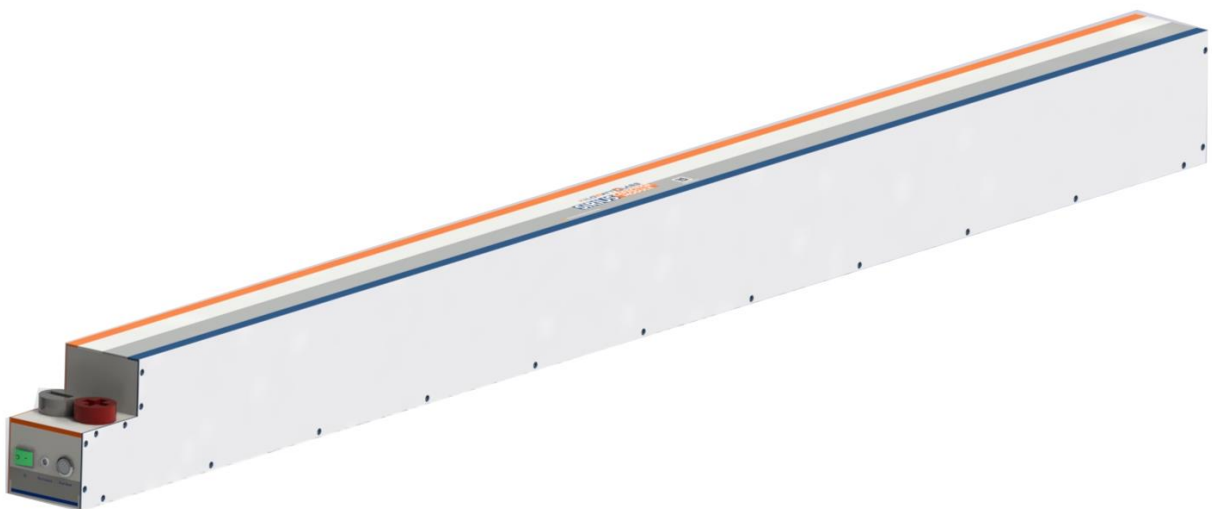

**2.2.2 Mechanical Drawings:**

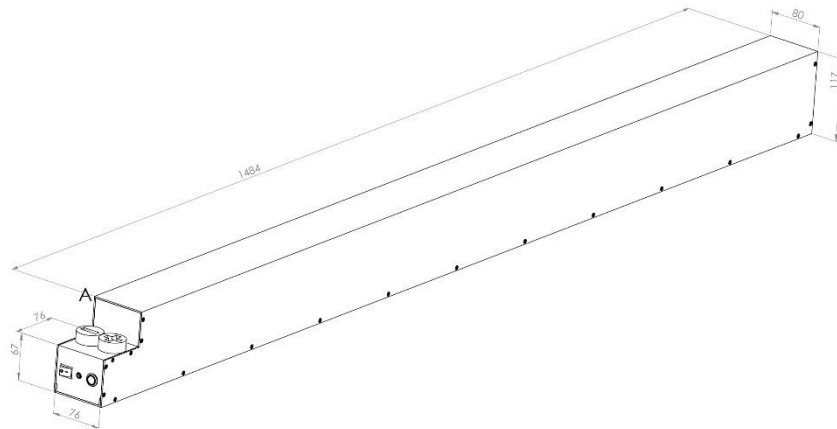

**Isometric View**

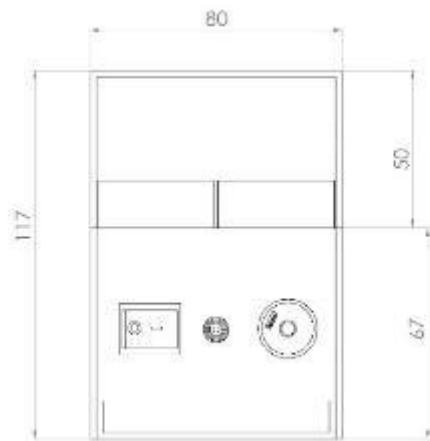

**Front View**



**Side View**





**Top View**

**2.2.3 Dimensions and Weight:**

Width	1560 mm
Depth	78 mm
Height	117 mm
weight	23 kg

**2.3 Product Description:**

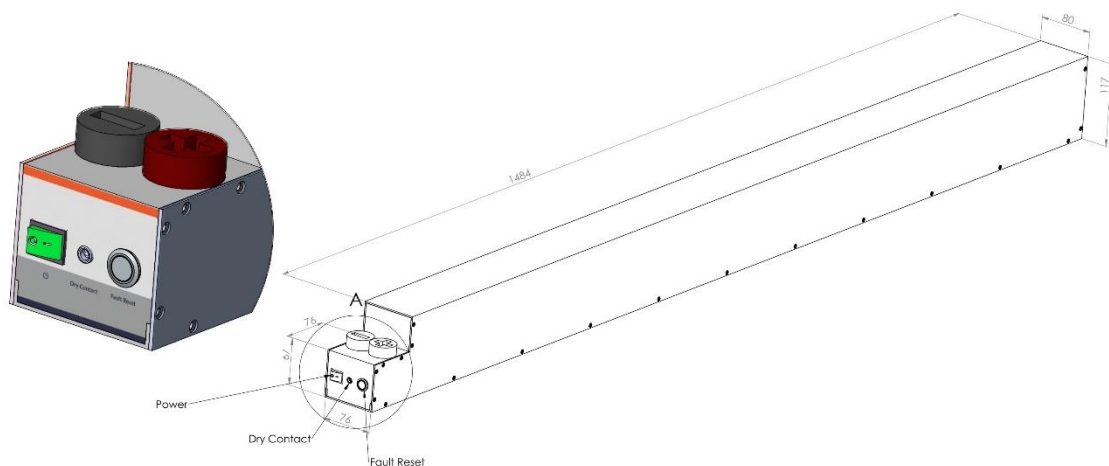

- |                 |                |
|-----------------|----------------|
| 1. Power Switch | 3. Fault Reset |
| 2. Dry Contact  | 4. Terminals   |

**1. Power Switch:**

When the power button is switched ON, the Module electronics are powered up and it will raise alarm during overvoltage, undervoltage, overcurrent and overtemperature. If the switch is OFF then there will be no alarm.

## 2. Fault Reset:

Fault Reset is a push button which is used to reset alarm raised during overvoltage, undervoltage, overcurrent and overtemperature faults.

## 3. Dry Contact:

Dry contact can refer to a secondary set of contacts of a relay circuit and can be connected to any power source or load. It gets isolated from the Module during fault conditions.

## 4. Terminals:

F12 terminals are used to connect the load or charger to the Module. There are also positive and negative cables in the jumper cable set. The **red** one is positive (+), the **black** one is negative (-).



## 3. Module Installation:

### 3.1 Inspection:

Inspect the shipping carton for visible damage including cracks, dents, deformation and other visible abnormalities prior to unpacking the Module. Document (photograph) any damage and report this to your Reseller as well as to the shipping agent immediately. Remove the Module from the shipping carton and retain the shipping materials until the unit has been inspected and is determined to be operational.

### 3.2 Safety Gear:

Installation must strictly follow the national safety regulations in compliance with the enclosure, installation, creepage, clearance, casualty, markings and segregation requirements of the end-use application. Installation must be performed by professional installers only. Switch OFF the system and check for hazardous voltages before altering any connection! Sirius Modules must be handled only by qualified and trained personnel. Installation should not exert bending or twisting torque to the Module enclosure.

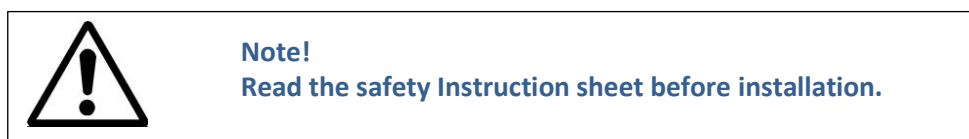

### 3.3 Unpacking and Contents Check:

Check the contents of the package. Only two items are included in the package.

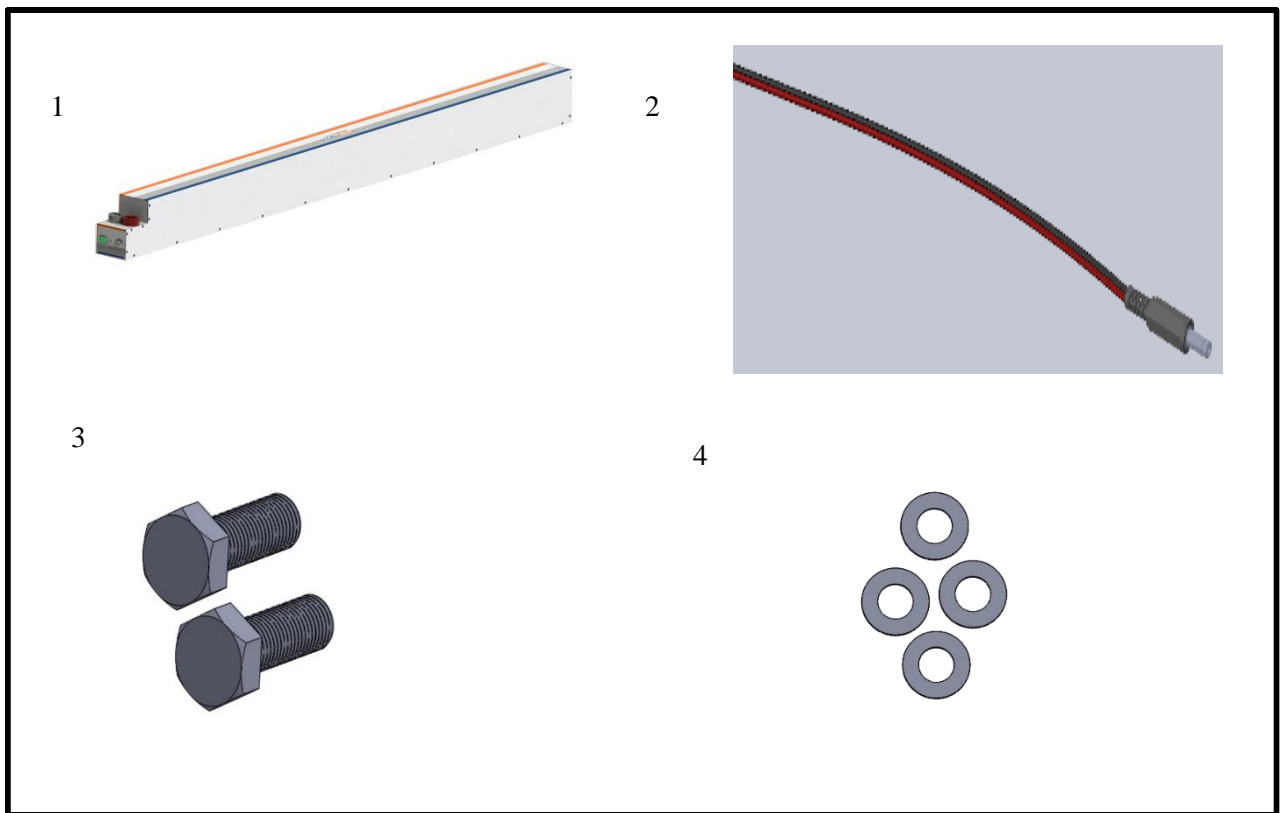

- 1) Sirius Capacitor Module: 1KWh12VDC
- 2) Dry Contact Cable
- 3) Screws × 2
- 4) Washers × 4

## 4. Operation Procedures:

### 4.1 Module Configuration:

Follow the steps below to switch ON the Module.

#### Step 1: Module Start-Up:

1. Connect Charger to switch ON the Module.
2. Turn ON the power switch button in order to give alarm during overvoltage, undervoltage, overcurrent and overtemperature faults.



The Module should only be operated within the specified voltage and temperature ratings.



Observe polarity indicated on Module. Do not reverse polarity.

**Step 2: Module Shut-Down:**

1. The Module can be shut down by disconnecting the load.



**Note!**  
Always turn **OFF** the Module when not in use because the Module is Self-Powered. It can result in faster Self-Discharge of the Module.

**5. Connecting Modules in Parallel or in Series:**

The capacity or voltage of the Module can be increased by connecting them in Parallel or Series combination respectively.

**5.1 Parallel Connection of Sirius Modules:**

Any number of Modules can be connected in parallel.

- **Steps to Connect Modules in Parallel:**

Refer to the parallel combination of the Sirius Modules as shown below and make your connection accordingly.

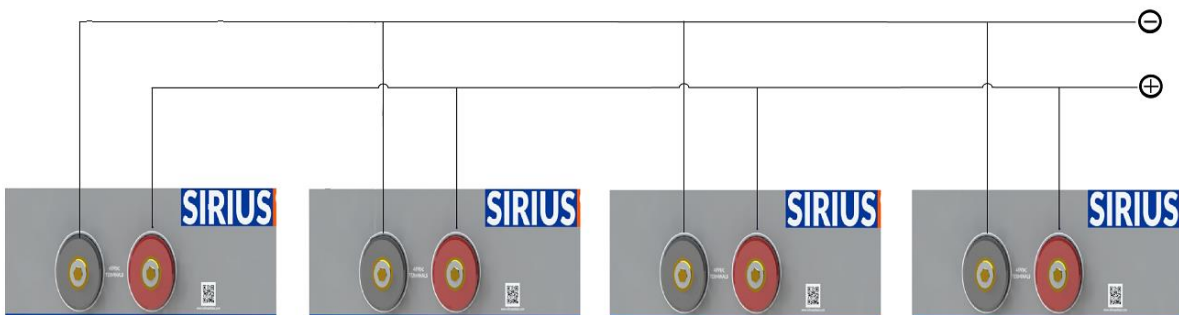

- Connect the **positive (+) terminal** of all Modules.
- Connect the **negative (-) terminal** of all Modules.

- Take out the output positive terminal and output negative terminal from the respective common point



**Caution!**  
Charge all the Modules to 100% SOC or same voltage level before connecting them in Parallel.

### 5.2 Series Connection of Sirius Modules:

A maximum of 8 Modules can be connected in Series.

- **Steps to Connect Modules in Series:**

Refer to the Series combination of the Sirius Modules as shown below and make your connection accordingly.

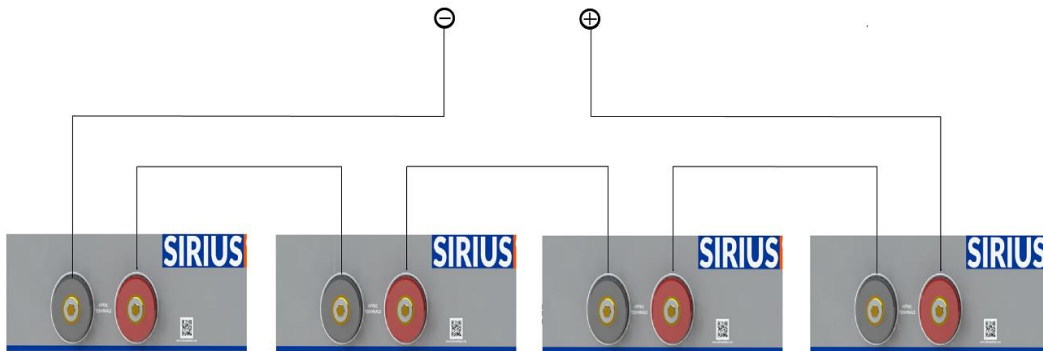

- Connect the positive (+) terminal of the first Module with the negative (-) terminal of the next Module.
- Take the Output Negative from first Module and Output Positive from the last Module.



**Caution!**  
Charge all the modules to 100% SOC or same voltage level before connecting them in Series.



**Note!**  
Modules cannot be connected in series-parallel combination under any circumstance.

**6. Recovery Procedure:**

Use the steps below to recover the Module.

1. A power supply having voltage range of 11V<sub>dc</sub> to 13.5V<sub>dc</sub> and current range of 1A to 10A will be required.
2. Connect the positive terminal of the power supply to the positive terminal of the F12 terminal and negative terminal of the power supply to the negative terminal of the F12 terminal.
3. Once the connection is done, turn ON the Charger.
4. The event may take several minutes depending on the power supply used.
5. At this stage, remove the power supply and leave the Module for normal recharge.

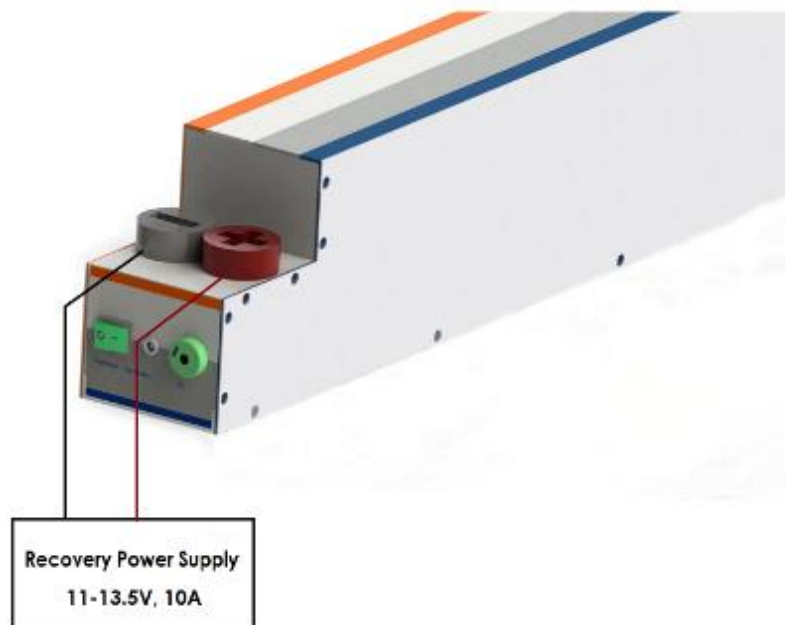

- **Recommended Charger for Recovery:**

Maximum Current	10 A
Recommended Voltage	11V-13.5V



**Caution!**  
Do not use more than 10A to recover the Module.

### 7. Automatic Safety Alarm:

The Module will automatically raise alarm under any excessive use conditions in order to prevent damage to itself and the connected equipment. Specified limits for excessive current, high voltage and low voltage are provided in Module’s technical data sheet.

Cause of Alarm	Description
Over-Current (OC)	When the Module has an OC fault, it means the current has increased beyond the cut-off limit of 50A. The Module will raise alarm which can be reset by the fault reset button.
Over-Voltage (OV)	When the Module has an OV fault, it means the voltage has increased beyond the cut-off limit of 13.5V. The Module will raise alarm which can be reset by the fault reset button.
Under-Voltage (UV)	When the Module has an UV fault, it means the voltage has reached beyond the cut-off limit of 11V. The Module will give alarm which can be reset by the fault reset button.
Over-Temperature	When the Module has an Over-Temperature fault, the buzzer alarms, which can be reset by the fault reset button.

### 8. Trouble Shooting:

Switch ON the power switch button on the front panel to determine the state of the Module. A warning state is triggered when a condition, such as voltage, current or temperature, is beyond design limitations. When the Module falls outside prescribed limits, it enters a warning state. When a warning is reported, the buzzer alarms.

The possible warning alarms are as follows:

Warning Messages	Description	Trouble Shooting
Over-Current (OC)	OC occurs when the current goes above 50A or when the Module is short-circuited. In this event, the buzzer alarms which can be reset by fault reset button.	Switch OFF the Module and check the continuity across the Module terminals to find whether there is a short circuit. In case of a short circuit, check the operating circuitry and clear the short circuit.
Over-Temperature (OT)	OT occurs when the Module temperature goes above 80°C. In this event, the buzzer alarms which can be reset by fault reset button.	Shut down the Module and check the surrounding temperature and ensure the ambient temperature is less than 80°C. If not leave the Module to cool till the temperature comes below 80°C.
Over-voltage (OV)	OV occurs when the Module voltage has increased the cut-off limit of 13.5V. In this event, the buzzer alarms which can be reset by fault reset button.	Check the charger's upper cut-off limit and ensure it is set below 13.5V. The Module becomes operational when the module's surface charge is cleared, and the voltage drops below 13.5V.
Under-voltage (UV)	UV occurs when the Module voltage goes beyond cut-off limit of 11V. In this event, the buzzer alarms which can be reset by fault reset button.	Check for the operating load lower cut-off limit and ensure it is above the lower threshold limit of 11V. The Module becomes operational when the voltage goes above 11V.

## 9. Features:

### 9.1 Key Features:

- Low power consumption.
- Detection of circuit board errors.



- Long service life.

## 9.2 Physical features:

1. Sirius Module has efficient relay that buzzer alarm in case of:

- High Voltage
- Low Voltage
- High Current
- High Module Temperature

## 10. Shelf Life:

Shelf life is the life of the Module in years from the date it is manufactured to the time it is first operated. The shelf life of supercapacitor cell is 10 years.

## 11. Maintenance:

The Sirius Capacitor Module does not require periodic maintenance.

## 12. Disposal:

Dispose according to local regulation.

## 13. Test Procedures:

### 13.1 Round Trip Efficiency Test:

Round Trip efficiency test is performed to evaluate the performance of the Module. There are three factors to be considered in the design of the test cycle for round trip efficiency.

- How to charge and discharge the Sirius Module.
- At what voltage to start and end the charge/discharge?
- At which points to do the measurement.

Considering the efficiency and cost involved in the production line, we used constant current load test method for Round trip efficiency characterization.

### Test Equipment:

- DC Charger test system or any other test system which can be used to charge and discharge Module with test cycle programming. We used **WRL48V80A27cd** DC Charger Motor for charging and **WRL-FDY48L20** Battery Discharge Tester for discharging.
-

**Test Temperature:**

- Room temperature 23°C ±2°C.
- Temperature controlled chamber can be used if testing at any environment other than room temperature.

**Test Current:**

- Different current within the maximum limit specified by the test equipment manufacturer can be applied to the test.

**Test Process:**

**Step 1: Rest (open circuit):**

- Record test time, test current, and voltage at the start of the test (t1, I1, V1).

**Step 2: Charge Cycle:**

- Charge voltage to its maximum voltage.
- Record test time, test current, voltage and total charge energy at the end of charge cycle (t2, I2, V2, E1).

**Step 3: Discharge Cycle:**

- Discharge Module to its minimum voltage.
- Record test time, test current, voltage and total discharge energy at the end of discharge cycle (t3, I3, V3, E2).

**Step 4: Round Trip Efficiency Calculation:**

$$\text{Round trip efficiency} = \left[ \frac{\text{total discharge energy (E2)}}{\text{total charge energy (E1)}} \right] \times 100$$